

Step 1.

- fold template where indicated.
- position template on door edge at desired lock height.
- firmly hold template and mark latch height and 54mm (2 1/8") lock body hole centre.
- measure door thickness and mark centre.
- drill 22mm (7/8") latch hole. NOTE: it is important to drill this hole squarely.
- drill pilot hole for lock body [suggested size 3mm (1/8")]. Then enlarge hole to 54mm (2 1/8"), drilling from both sides of the door.

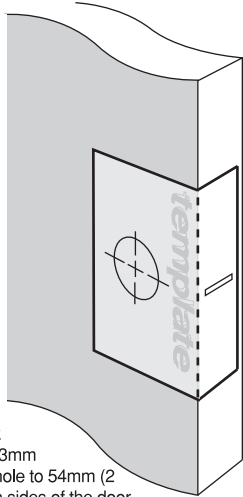

please note:

for a single cylinder deadbolt (ie. with internal turnbutton) ensure stem A is on the internal side of the door. If this is not the case, rehand lock body by removing grub-screw with allen key provided, turn cylinder to desired direction and re-fasten.

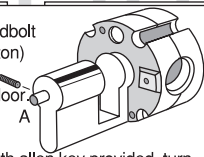

Step 2.

- mark and chisel latch faceplate to a recess of 3.5mm. Use latch carrier as a template.
- insert lock body into 54mm (2 1/8") hole.
- insert bolt carrier through 22mm (7/8") hole into lock body assembly and fix with 2 screws. Ensure T-shape at rear of bolt carrier is upright!

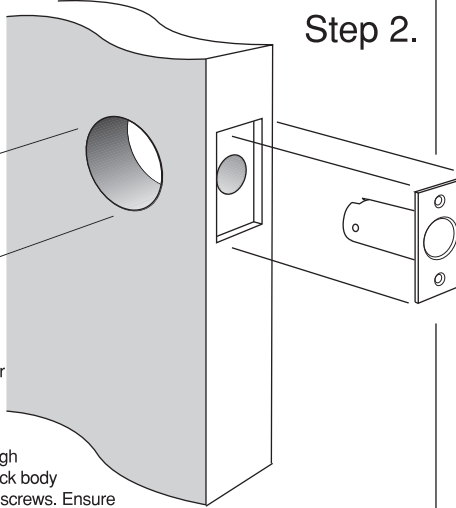

Step 3.

Note: The faceplate plastic shim MUST be installed to ensure correct operation of deadbolt.

- insert key and rotate towards edge of the door.
- insert bolt until stop and rotate key away from edge of the door.
- if bolt does not operate properly repeat above steps.
- extend bolt and install plastic faceplate shim and faceplate onto it. Press firmly onto door edge and screw into position.

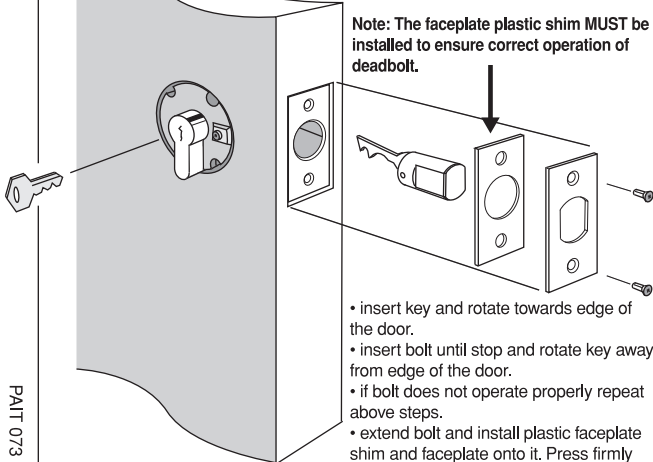

Step 4.

- screw external escutcheon to snap fix assembly. NOTE: do not overtighten screws. Ensure snap fix assembly is located on the interior side of the door.
- insert key and rotate to check lock function. Please note that deadbolt requires 180 degree key rotation to achieve deadlocking.
- if bolt does not operate properly repeat step 3.

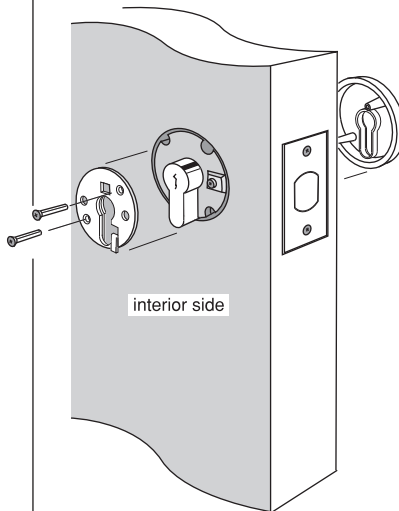

NOTE: carefully follow these instructions when installing. do not overtighten screws as this may impede final assembly of internal escutcheon. use of power driver is not recommended. screws to be tightened to a recommended 2.5Nm torque.

PART 073



fit here on door edge

mark centre-line of latch hole

fit here on door edge

backset 60mm (2 3/8")

backset 60mm (2 3/8")

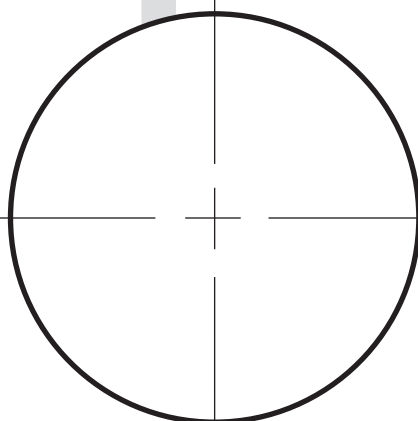

installation template for **852** double cylinder and **847** single cylinder deadbolts with 15mm throw

Step 5.

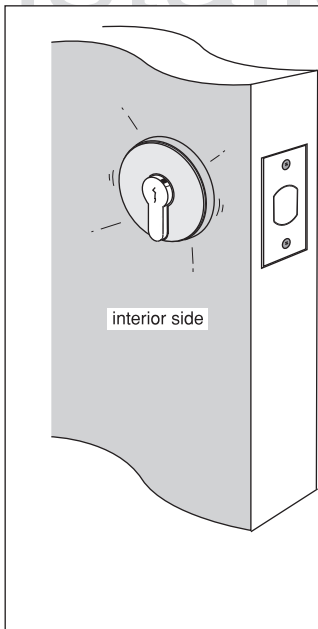

interior side

- snap fix internal escutcheon to the door.



- for single cylinder applications install internal turnbutton now by tightening grub-screw on to protruding shaft.

Step 6.

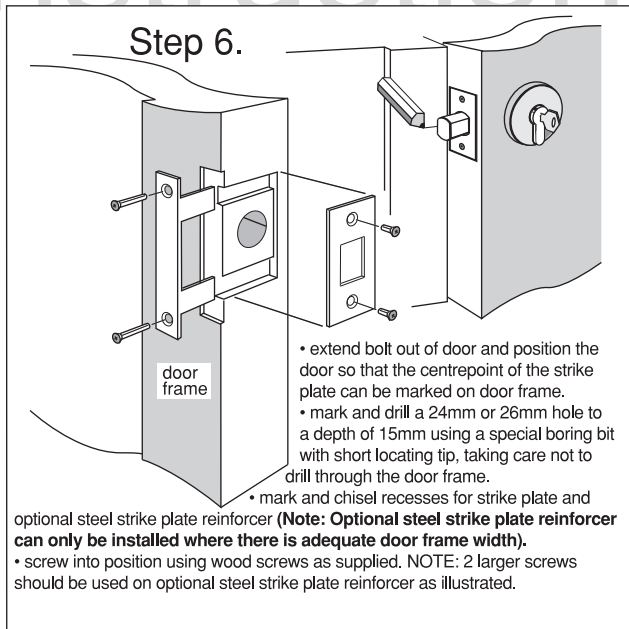

door frame

- extend bolt out of door and position the door so that the centrepoint of the strike plate can be marked on door frame.
- mark and drill a 24mm or 26mm hole to a depth of 15mm using a special boring bit with short locating tip, taking care not to drill through the door frame.
- mark and chisel recesses for strike plate and optional steel strike plate reinforcer (Note: **Optional steel strike plate reinforcer can only be installed where there is adequate door frame width.**)
- screw into position using wood screws as supplied. NOTE: 2 larger screws should be used on optional steel strike plate reinforcer as illustrated.

PAIT 073

NOTE: carefully follow these instructions when installing. screws to be tightened to a recommended 2.5Nm torque.

