

Installation Instructions for 757 Rebate Kit

Designed for standard rebated doors

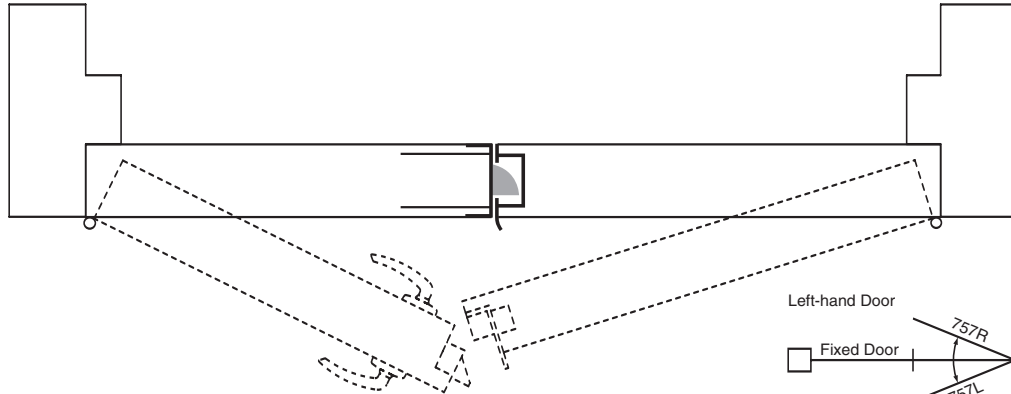

- Prior to installation, check that you have the correct left or right-handed rebate kit to suit your particular door opening by referring to the diagram below.
- Hold rebate kit onto the door and ascertain which door leaf will be for the adaptor plate (with lock) and which door leaf will be the fixed door for the strike plate.

NOTE: Carefully follow these instructions when installing. Screws to be tightened to a recommended 2.5Nm torque.

Diagram A.

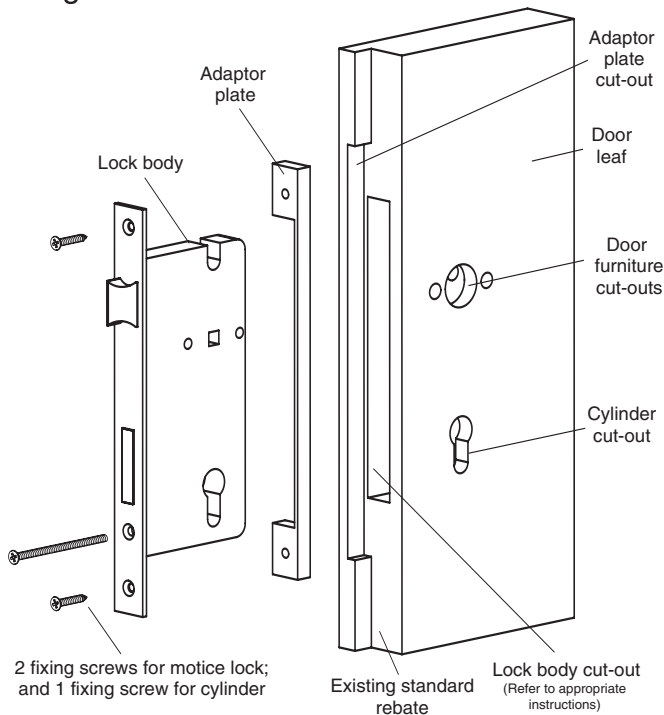

Mark and install adaptor plate (with lock) to door leaf nominated for lock

- Centralise the adaptor plate of the rebate kit to the door thickness on the nominated door leaf. Using the adaptor plate as a template, mark out the areas to be chiselled for the adaptor plate, as shown in Diagram A.
- Mark out the lock body installation cut-outs and relevant holes through the door face, according to the appropriate instructions supplied with lock and door furniture. Mortice out the door accordingly.
- After all the timber has been removed, attach both the lock body with the adaptor plate to the door and fix with the screws supplied with mortice lock- refer Diagram A.
- Refer Diagram B for the final view of fitted lock and adaptor plate in door.

Diagram B.

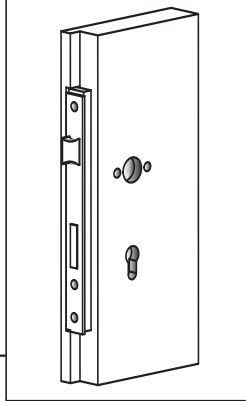
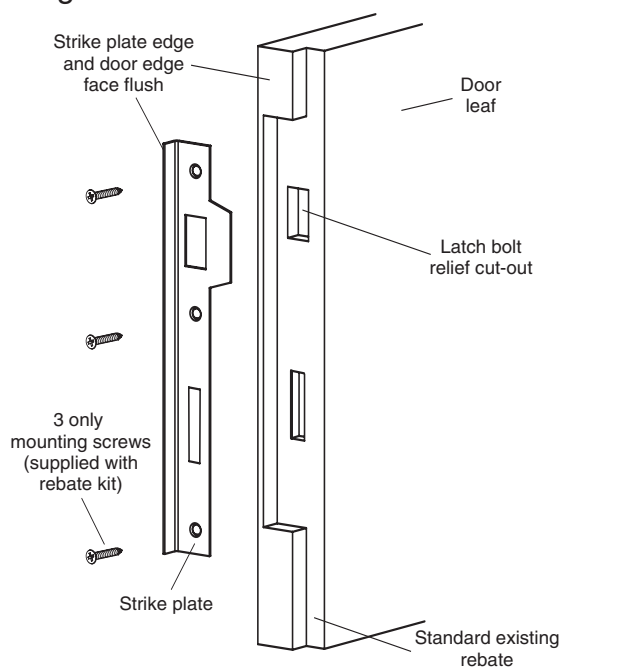

Diagram C.



Mark and install strike plate to door leaf nominated for strike plate

- With deadbolt extended, close the door leaf (with lock) against the fixed door leaf – i.e., the door leaf that will incorporate the strike plate.
- On the fixed door leaf, mark centre points for latchbolt and deadbolt for the respective cut-outs in strike plate.
- Centralise the strike plate to the door thickness and to the above centre points for latchbolt and deadbolt, and using the strike plate as a template, mark out the areas to be chiselled for the strike plate, as shown in Diagram C.
- Ensure strike plate edge and door edge face are flush as shown in Diagram C.
- Install strike plate with 3 screws supplied in rebate kit, as shown in Diagram C.
- Refer Diagram D for final view of fitted strike plate in door.

Diagram D.

