

# UNIQUE SASH BALANCES

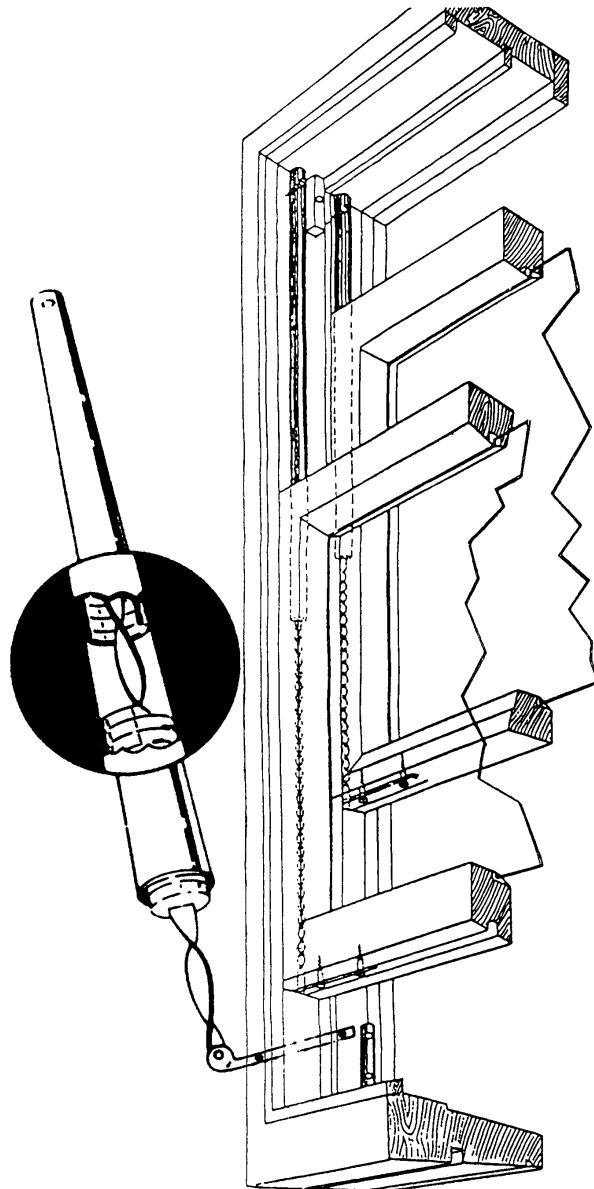

## Introduction

Gainsborough UNIQUE Sash Balances are ideal for the replacement of existing Sash Balances or for use in the installation of new sash windows.

Renowned for reliable operation and performance, Gainsborough Unique Sash Balances feature strong spring mechanism and high quality materials and workmanship.

Choose from a selection of sash balance types with specific tube diameter specifications to suit the rebate grooves in common sash windows:

Type 'D'-14mm tube for 16mm rebate; Type 'A' - 9.5mm tube for 11mm rebate; Type 'B' - 12.4mm tube for 14mm rebate and Type 'HD' - 12.4mm tube for 14mm rebate - heavy duty.

A variety of tube lengths are also available for each of the above sash balance types, designed to suit a multitude of sash window sizes produced.

Gainsborough Unique Sash Balances are also offered in a range of popular colours. Please refer to page 2 under "Sash Balance Types, Colours and Specifications" for colours available by specific sash balance type.

## Instructions to determine the correct type of sash balance

The correct type of sash balance required for the window is governed by the overall size of the window, the weight of the sash window and the rebate size in the sash window.

Follow these steps to ensure specification of the correct sash balances for the windows concerned.

## Steps to follow for selection

### 1. Measure overall window height accurately

Measure the overall window height from the inside top of the head to the inside bottom of the sill, as identified by (A) in the FITMENT CHART below:

### FITMENT CHART

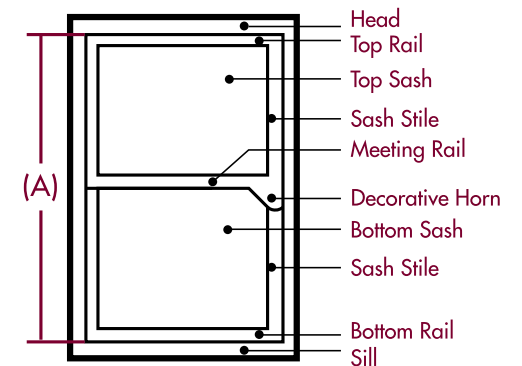

## Gainsborough Hardware Industries Limited

Head Office:  
190 Whitehorse Rd, Blackburn, VIC 3130  
or PO Box 330, Blackburn, VIC 3130  
A.B.N. 25 004 792 269

Telephone: (03) 9877 1555  
E-mail: sales@gainsboroughhardware.com.au  
Sales Hotline: 13 14 18 Sales Fax Hotline: 13 18 14  
www.gainsboroughhardware.com.au

# UNIQUE SASH BALANCES

## 2. Weigh the sash window to confirm spring size

Disconnect the existing balance by unscrewing the feet from underneath the window sashes and place the bottom sash window on a set of bathroom scales.

Weigh the bottom sash window.

This information will be needed to confirm that the standard spring in the selected sash balance part number will carry the window weight – refer “Weight Table” on page 3.

## 3. Determine the rebate size in the window for tube diameter

Sash windows are normally rebated to receive one of the sash balance types shown under: “Sash Balance Types, Colours and Specifications”. Measure the rebate grooving in the window or alternatively measure the diameter of the existing sash balance.

This will determine the sash balance TYPE required- use the selection drawings below to determine which sash balance type is needed.

## 4. What type of foot does your existing balance have?

The foot of the balance is the part of the balance that attaches to the underneath of the sash.

Gainsborough sash balances are supplied standard with the “HA-1” foot as shown below:

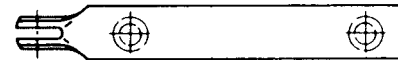

HA-1 Foot  
Part No. APT01/HA1

Other feet types are available as shown below. (If other feet types are needed, please specify details on order.)



HA-2 Foot  
Part No. APT01/HA2



UC-1 Foot-detachable  
Part No. APT01/UC1

## 5. Select Sash Balance Required

The “Sash Balance Selection Table” shown at right can be used to specify the sash balance numbers and relevant part numbers:

The overall height of the window, as determined in Step 1, will fall between a size range shown in **Column A**.

**Column B** shows the tube length for the bottom sash balance for the window range selected from column A.

**Column C** shows the relevant bottom sash balance number for the window range.

- For the matching top sash balance, specify 2 sizes shorter by using the chart.
- However, if the top sash window features 50mm horn, then the top sash balance number would be the same as the bottom sash balance number. (For top sash window with an alternative horn size, please check balance number required.)

**Columns D-H** allow the identification of the corresponding Gainsborough product part number for the sash balance type. The sash balance type is dependent on the tube diameter to suit the rebate size in window - refer “Sash Balance Types, Colours and Specifications”.

**NOTE:**  
The above instructions assume that both top and bottom sashes are of equal size and meet at the mid rail.

SASH BALANCE TYPES, COLOURS AND SPECIFICATIONS

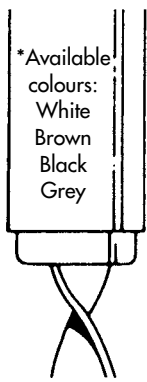
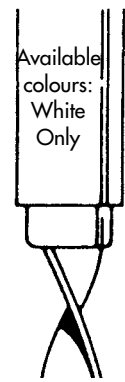
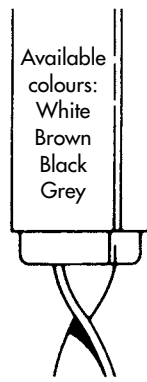
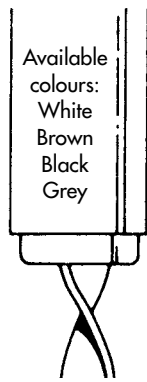
 <p>*Available colours: White Brown Black Grey</p>	 <p>Available colours: White Only</p>	 <p>Available colours: White Brown Black Grey</p>	 <p>Available colours: White Brown Black Grey</p>
<p>TYPE 'D' STANDARD 14mm DIAMETER TO SUIT 16mm x 16mm REBATE SASH WEIGHT UP TO 13.5kg</p>	<p>TYPE 'A' 9.5mm DIAMETER TO SUIT 11mm x 11mm REBATE SASH WEIGHT UP TO 8kg</p>	<p>TYPE 'B' 12.4mm DIAMETER TO SUIT 14mm x 14mm REBATE SASH WEIGHT UP TO 13.5kg</p>	<p>TYPE 'HD' 12.4mm DIAMETER TO SUIT 14mm x 14mm REBATE SASH WEIGHT UP TO 17.5kg</p>

\* Note: Type 'D' in visual pack is available in grey only



# UNIQUE SASH BALANCES

SASH BALANCE SELECTION TABLE

Visual Pack (2 per pack)  Special Order (1 per pack)

Column A	Column B	Column C	Column D	Column E	Column F	Column G	Column H	
For window sizes over mm	For window sizes up to mm	Tube length mm	Sash Balance No.	Type 'D' Sash Balance Part No. EACH	Type 'D' Sash Balance Part No. [VISUAL PACK 2 PER PACK]	Type 'A' Sash Balance Part No. EACH	Type 'B' Sash Balance Part No. EACH	Type 'HD' Sash Balance Part No. EACH
635mm	690mm	330mm	10	A01D/10		A01A/10	A01B/10	
690mm	735mm	355mm	11	A01D/11		A01A/11	A01B/11	
735mm	785mm	380mm	12	A01D/12		A01A/12	A01B/12	
785mm	840mm	405mm	13	A01D/13		A01A/13	A01B/13	
840mm	890mm	430mm	14	A01D/14		A01A/14	A01B/14	
890mm	940mm	455mm	15	A01D/15		A01A/15	A01B/15	
940mm	990mm	485mm	16	A01D/16	A01D/16V	A01A/16	A01B/16	
990mm	1040mm	510mm	17	A01D/17	A01D/17V	A01A/17	A01B/17	
1040mm	1090mm	535mm	18	A01D/18	A01D/18V	A01A/18	A01B/18	
1090mm	1145mm	560mm	19	A01D/19	A01D/19V	A01A/19	A01B/19	
1145mm	1195mm	585mm	20	A01D/20	A01D/20V	A01A/20	A01B/20	A01HD/20
1195mm	1245mm	610mm	21	A01D/21	A01D/21V	A01A/21	A01B/21	A01HD/21
1245mm	1295mm	635mm	22	A01D/22	A01D/22V	A01A/22	A01B/22	A01HD/22
1295mm	1345mm	660mm	23	A01D/23	A01D/23V	A01A/23	A01B/23	A01HD/23
1343mm	1395mm	690mm	24	A01D/24	A01D/24V	A01A/24	A01B/24	A01HD/24
1395mm	1450mm	715mm	25	A01D/25	A01D/25V	A01A/25	A01B/25	A01HD/25
1450mm	1500mm	735mm	26	A01D/26	A01D/26V	A01A/26	A01B/26	A01HD/26
1500mm	1550mm	760mm	27	A01D/27	A01D/27V	A01A/27	A01B/27	A01HD/27
1550mm	1600mm	785mm	28	A01D/28	A01D/28V	A01A/28	A01B/28	A01HD/28
1600mm	1650mm	815mm	29	A01D/29	A01D/29V	A01A/29	A01B/29	A01HD/29
1650mm	1700mm	840mm	30	A01D/30	A01D/30V	A01A/30	A01B/30	A01HD/30
1700mm	1755mm	865mm	31	A01D/31	A01D/31V	A01A/31	A01B/31	A01HD/31
1755mm	1805mm	890mm	32	A01D/32	A01D/32V	A01A/32	A01B/32	A01HD/32
1805mm	1855mm	915mm	33	A01D/33	A01D/33V			A01HD/33
1855mm	1905mm	940mm	34	A01D/34				A01HD/34
1905mm	1955mm	965mm	35	A01D/35				A01HD/35
1955mm	2005mm	990mm	36	A01D/36				A01HD/36
2005mm	2055mm	1015mm	37	A01D/37				A01HD/37
2055mm	2110mm	1040mm	38	A01D/38				A01HD/38
2110mm	2160mm	1065mm	39	A01D/39				A01HD/39
2160mm	2210mm	1090mm	40	A01D/40				A01HD/40
2210mm	2260mm	1115mm	41	A01D/41				A01HD/41
2260mm	2310mm	1145mm	42	A01D/42				A01HD/42
2310mm	2360mm	1170mm	43	A01D/43				A01HD/43
2360mm	2415mm	1195mm	44	A01D/44				A01HD/44
2415mm	2465mm	1220mm	45	A01D/45				A01HD/45
2465mm	2515mm	1245mm	46	A01D/46				A01HD/46
2515mm	2590mm	1270mm	47	A01D/47				A01HD/47
2590mm	2615mm	1295mm	48	A01D/48				A01HD/48

## WEIGHT TABLE:

From the information gathered in step 2, use the "Weight Table" to check and confirm if the sash balance chosen, with its standard spring specification, will carry the weight of the window (when used as a set).

If the weight of the window is heavier than the specifications, a non-standard spring can be arranged.

### WEIGHT TABLE

#### Type 'D' Sash Balance

14mm tube diameter to suit 16mm by 16mm rebate in sash window

Sash Balance Number	Standard Spring	Will carry the following weight range
Up to 25	2 spring	Up to 6kg
26 - 32	3 spring	6 - 9kg
33 and over	4 spring	9 - 13.5kg

#### Type 'A' Sash Balance

9.5mm tube diameter to suit 11mm by 11mm rebate in sash window

Sash Balance Number	Standard Spring	Will carry the following weight range
10 - 18	2 spring	Up to 6kg
19 - 32	3 spring	6 - 8kg

#### Type 'B' Sash Balance

12.4mm tube diameter to suit 14mm by 14mm rebate in sash window

Sash Balance Number	Standard Spring	Will carry the following weight range
10 - 24	2 spring	Up to 6kg
25 - 32	3 spring	6 - 8kg
33 and over	4 spring	8 - 13.5kg

#### Type 'HD' Sash Balance (Heavy duty for windows 14 - 17.5kg)

12.4mm tube diameter to suit 14mm by 14mm rebate in sash window

Sash Balance Number	Standard Spring	Will carry the following weight range
20 - 48	0 spring	14 - 17.5kg

\* Window weight ranges are carried by 2 of the selected sash balance number

# UNIQUE SASH BALANCES

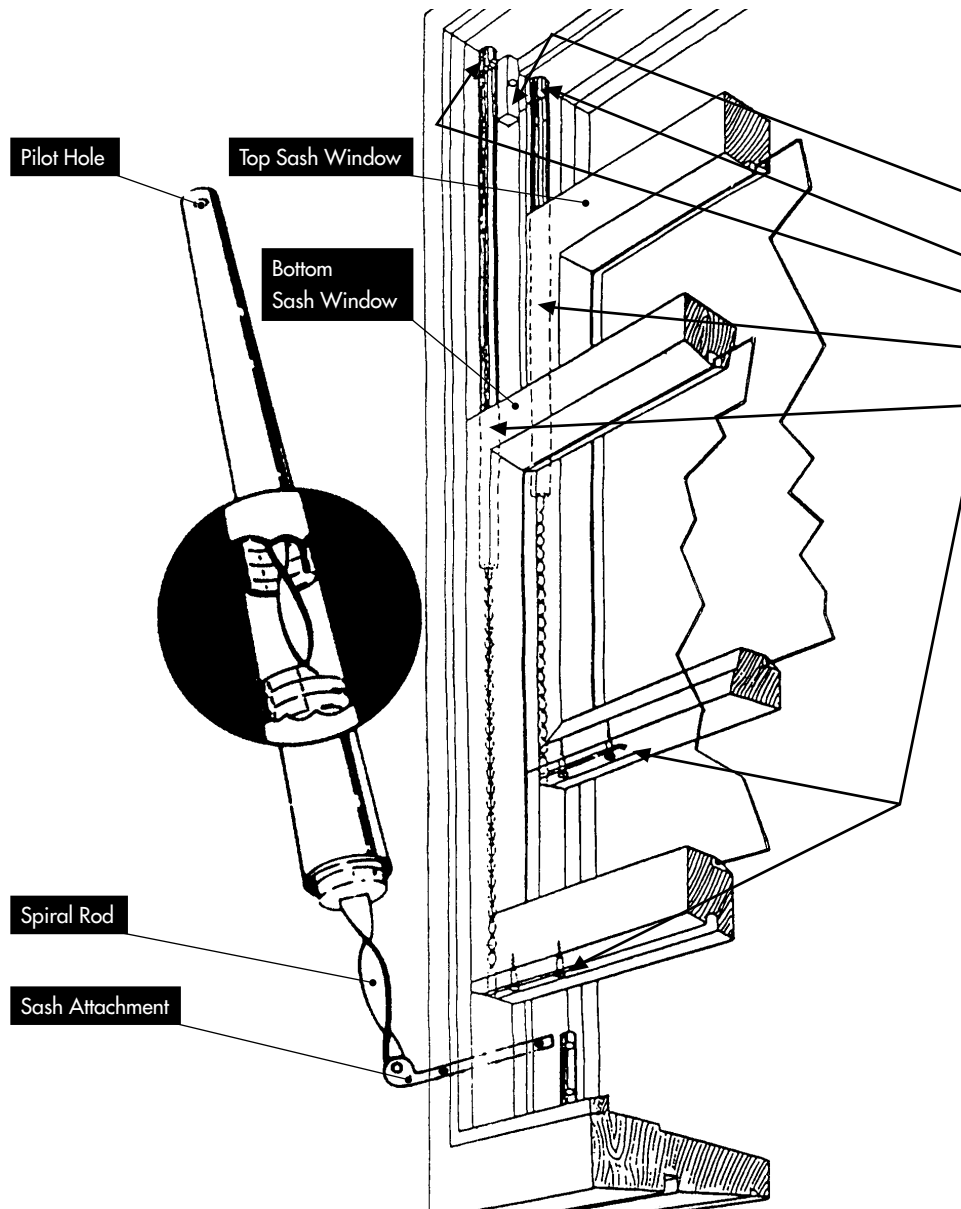

## INSTRUCTIONS ON HOW TO INSTALL A GAINSBOROUGH UNIQUE SASH BALANCE

### Shown for Type 'A', Type 'B' and Type 'D' Sash Balances

Note: Where the top and bottom window sashes are NOT of equal height, sash balances should be placed in grooves of the sash window before the sashes are fitted to the frame.

- Ensure that existing stop blocks are secure.
- Ensure sash balance tubes align with grooves in sash.
- Fasten the **top sash balance** (short balance) tight against head jamb with drive screw through pilot hole.
- Fasten **bottom sash balance** (long balance) tight against head jamb with drive screw through pilot hole.

### • 'Short' Balances for Top Sash

### • 'Long' Balances for Bottom Sash

### • Sash Attachment

To adjust balances

1. Open bottom window to its highest position. If the spiral rod has unwound from inside the sash balance, gently wind back up to bring the sash attachment (foot) to bottom rail of sash window. To load the sash balance, hold sash attachment (foot) firmly and pull down to a convenient position and apply three or four turns to the LEFT (clockwise). Temporarily secure attachment to the bottom of the sash window with a small nail.
2. Repeat operation No. 1 for opposite side of bottom sash, ensuring you have the same number of turns for both sides.
3. Raise and lower sash. If the sash falls at the highest position, add a turn or two (no more than a total of six turns should be necessary); if harder to pull down than to lift, release a turn until the sash operates evenly up and down. Again, ensure that you have an equal number of turns on both sides. Screw attachments firmly into position.
4. Repeat for the top sash.

### DO NOT DO THIS

1. Do not bend spiral rod when putting on tension turns.
2. When adjusting the balance, do not wind more than necessary to hold sash in its highest position. Too many turns will add unnecessary friction.
3. Do not allow the sash attachment to foul the jamb.